

HERTELL S. COOP.



B VACUUM PUMP

HERTELL S. COOP.

Index.

	Pag.
1.- Introduction	3
1.1.- Definition.	
1.2.- Models.	
2.- Setting up	4
3.- Material	6
3.1.- Foundry.	
3.2.- Vanes.	
4.- Technical Specifications	8
4.1.- Dimensions.	
4.2.- Air flow.	
5.- Parts list. Drawings	10
6.- Warranty	11

1.- INTRODUCTION.

1.1. Definition.

- Rotary fibre blade pump on eccentric rotor for vacuum tankers. Compact and on-line design.
- Continuous lubrication by vacuum. Equipped with ventilator. Patent N° ES 9602.207

1.2. Models.

B-400, B-800, B-1.600 Y B-2.200.

- .- Drive: 1.500 r.p.m. Clockwise.
- .- Axle Ø 19 mm for B-400 and B-800. Key.
- .- Axle Ø 28 mm for B-1.600 y B-2.200. Key.

2.- SETTING UP.

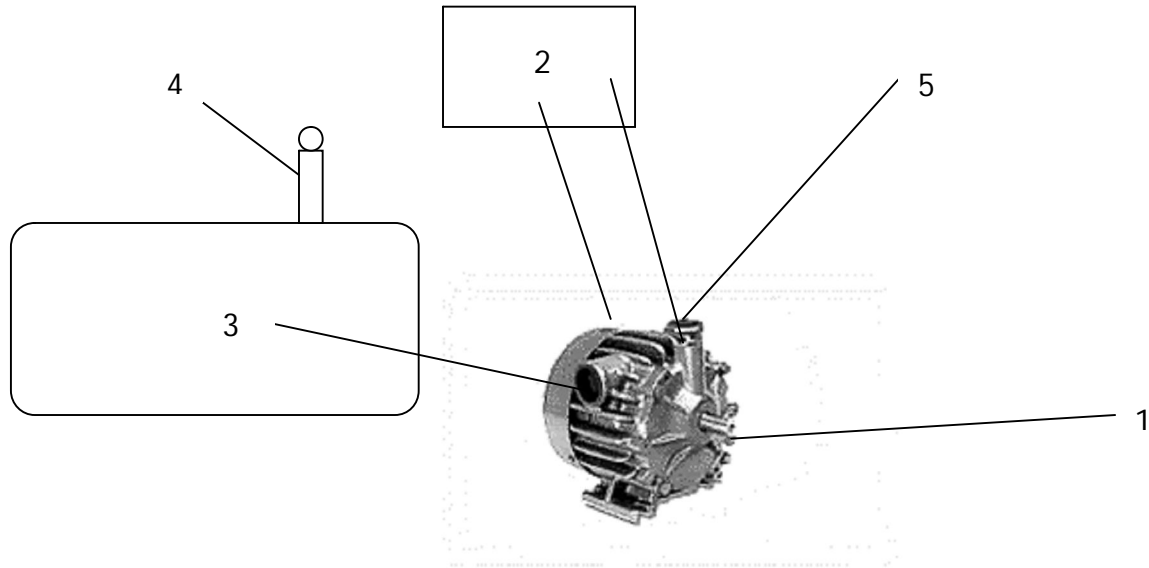

- 1.- Drive.
- 2.- Oil tank.
- 3.- Vacuum tank.
- 4.- Safety valve.
- 5.- Exhaust.

Setting up examples:

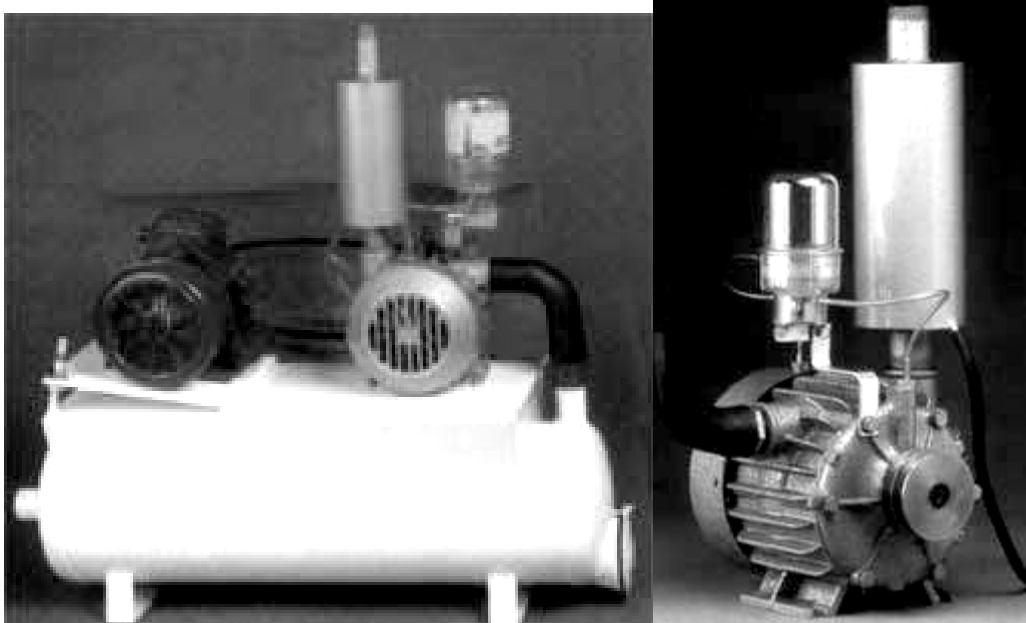

- Each B pump can run continuously if the vacuum rate is limited to 50 kPa (15"Hg). To do that it is necessary to set up a safety valve on the vacuum system (4).
- It is recommended a pipe of 1" ¼ diameter for the B-400 pumps, a 1" ½ pipe for the B-800 pumps and a de 2" pipe for the B-1600 and B-2200 pumps.
- Being the maximal vacuum rate of all the pumps very similar the choice of the pump will be done depending on the air flow needed.
- Each unit is delivered with two drop feeders to be connected to the oil tank. One maintenance leaflet is also provided with each unit.

3.- MATERIAL.

3.1. Foundry.

- Pumps body is manufactured in steel-like GGG-60 foundry, three times more resistant than normal cast iron.

This kind of material guarantees no breaking of the body under misuse of the pump.

By request a Certificate of the foundry composition is available.

3.2. Vanes.

- Free asbestos vanes with graphite.

All the B pumps are equipped with 4 vanes.

3.2.1.- Vanes lubrication.

When pump is operating the vanes have to be lubricated. Each vacuum pump has been tested and therefore the drop feeders have been regulated before leaving the Works. Normal lubrication flow is between 15 and 20 drop per minute. Should the drop feeders need to be adjusted, then release set screw M and adjust turning the nipple N (Picture 2). If the nipple is turned in clockwise sense, the oil flow decreases, and it increases with the opposite operation. After adjusting, tighten set screw M again.

(Picture 2)

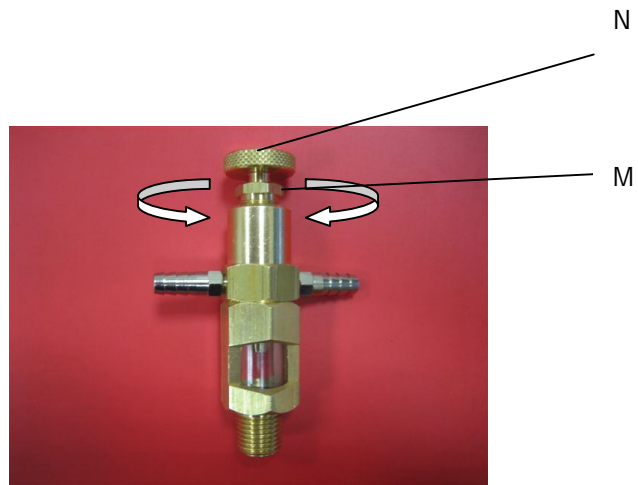

Viscosity of the vanes lubrication oil: ISO VG - 68

4.- TECHNICAL SPECIFICATIONS.

4.1. Dimensions.

Mod.	Weight kG	r.p.m.	L/min 50 kPa	Kw	DIMENSIONS									
					A	B	C	D	E	F	G	H	I	J
B-400	15	1.500	450	1,5	188	128	1 1/4"	238	90	70	35	100	19	190
B-800	23	1.500	850	2,2	188	128	1 1/2"	308	90	70	35	100	19	190
B-1600	33	1.500	1.600	4,0	260	175	2"	348	142	105	42	144	28	265
B-2200	40	1.500	2.200	6,0	260	175	2"	398	142	105	42	144	28	265

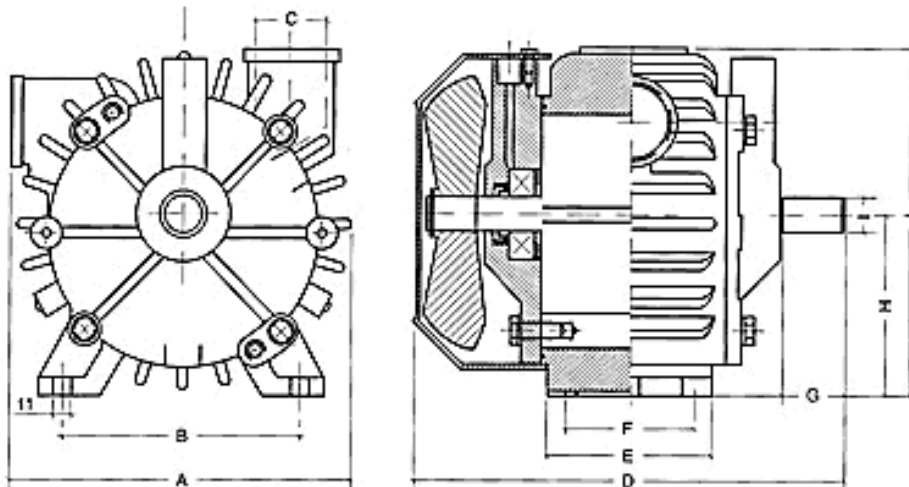

4.2. Air flow.

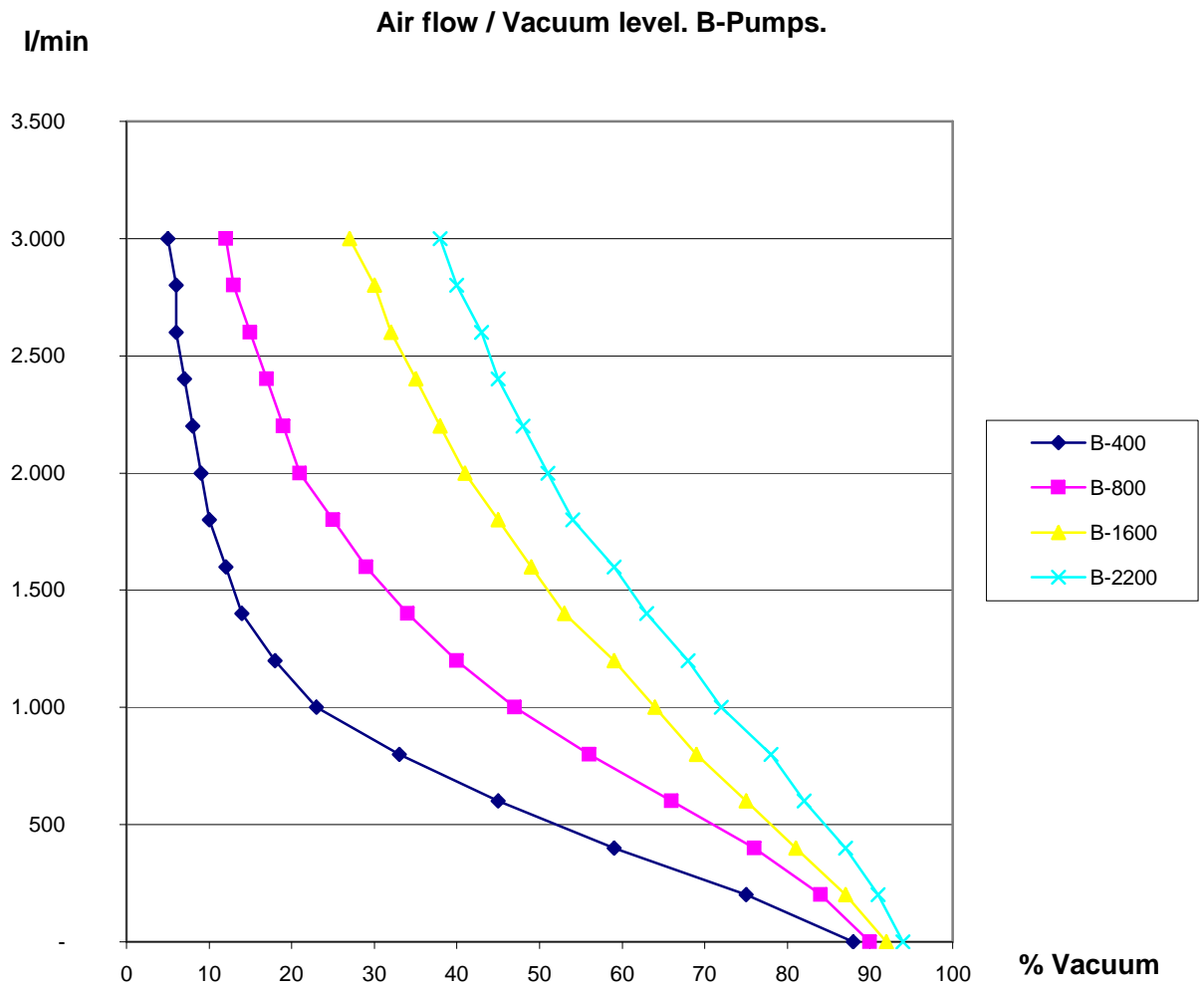

Litres / min. Rotor turning speed: 1.500 r.p.m.

5. PARTS LIST. DRAWINGS

Following list and drawing identify the spare parts of any B pump:

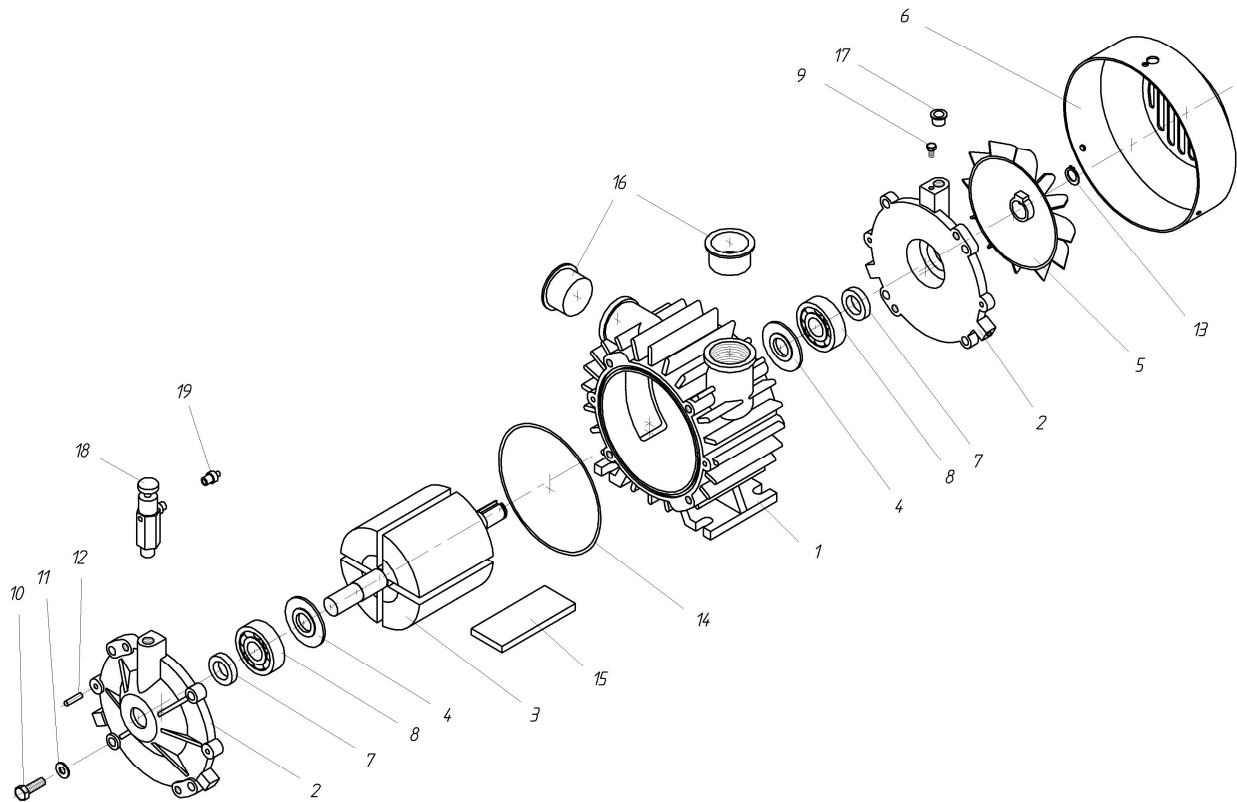

Ref.	Denomination	01BO022008	N. 8. Bearing for B-1600/2200 6207
01BO004001	N. 1. Body for B- 400	01BO022009	N. 9. Screw for B- 400/2200
01BO008001	N. 1. Body for B- 800	01BO008010	N.10. Screw for B- 400/800
01BO016001	N. 1. Body for B-1600	01BO022010	N.10. Screw for B-1600/2200
01BO022001	N. 1. Body for B-2200	01BO008011	N.11. Washer for B- 400/800
01BO008002	N. 2. Cover for B- 400/800	01BO022011	N.11. Washer for B-1600/2200
01BO022002	N. 2. Cover for B-1600/2200	01BO022012	N.12. Pin for B- 400/2200
01BO004003	N. 3. Rotor for B- 400	01BO008013	N.13. E-19 Ring para B- 400/800
01BO008003	N. 3. Rotor for B- 800	01BO022013	N.13. E-25 Ring for B-1600/2200
01BO016003	N. 3. Rotor for B-1600	01BO008014	N.14. O-Ring for B- 400/800
01BO022003	N. 3. Rotor for B-2200	01BO022014	N.14. O-Ring for B-1600/2200
01BO008004	N. 4. Spacer bushing for B-1600/2200	01BO004015	N.15. Vane for B- 400 (100x42x7,5) 4
01BO022004	N. 4. Spacer bushing for B-400/800	01BO008015	N.15. Vane for B- 800 (170x42x7,5) 4
01BO008005	N. 5. Ventilator for B- 400/800	01BO016015	N.15. Vane for B-1600 (160x57x7,5) 4
01BO022005	N. 5. Ventilator for B-1600/2200	01BO022015	N.15. Vane for B-2200 (210x57x7,5) 4
01BO008006	N. 6. Cover for B- 400/800	01BO008016	N.16. 1" 1/2 Plug for B- 800
01BO022006	N. 6. Cover for B-1600/2200	01BO004016	N.16. 2" Plug for B-1600/2200
01BO008007	N. 7. Seal for B- 400/800 20x32x7	01BO022016	N.16. Plug 1" 1/4 for B- 400
01BO022007	N. 7. Seal for B-1600/2200 35x55x10	01BO022017	N.17. Plug 1/4" for B- 400/2200
01BO008008	N. 8. Bearing for B- 400/800 6304	01BO022018	N.18. Drop feeder for B- 400/2200

6.- Warranty.

Each pump is checked in our Test-bank by vacuum before leaving our Works. Thereafter each vacuum pump is identified with a manufacture number. (Sticker on the ventilator).

Our pumps have one year warranty after delivery against defects of material or assembly. HERTELL S.COOP is not responsible of direct or indirect costs caused by the pump misuse. In case of reclamation, it is decision of Hertell S.Coop. to verify the origin of the claim. It is the responsibility of the tank manufacturer to verify that the pump is going to be used according to the advised instructions.

The vacuum pumps fulfil the 89/392/CEE directive about machines and its posterior modification 98/37/CEE, according to the norms concerning vacuum pumps and compressors UNE - EN 1012-1 and UNE - EN 1012-2. By request a certificate according to this directive is available.

HERTELL S.COOP.

Industrialdea 2
20267 Ikaztegieta

SPAIN

Tel: + 34 943 653240

Fax: + 34 943 653332

E-mail: info@hertell.net

<http://www.hertell.net>