

# Owner's Manual & Operating Instructions

*607 Challenger Series Rotary Vane Vacuum Pumps*



Visit our web site to download pump setup guides,  
brochures and other technical information.



# 607 Challenger

## Owner's Record

**Date of Purchase:** \_\_\_\_\_

**Purchased from:** \_\_\_\_\_

**Serial Number:** \_\_\_\_\_

© 2012 National Vacuum Equipment, Inc.  
Revision: 4 (Release) March 2012

*No part of this manual may be reproduced without the written permission of  
National Vacuum Equipment, Inc.*

# IMPORTANT INFORMATION FOR INSTALLING PUMP

607 CHALLENGER SERIES PUMPS AERIAL VIEW

SHADED AREA MUST BE KEPT CLEAR  
FOR SERVICING THE FILTER

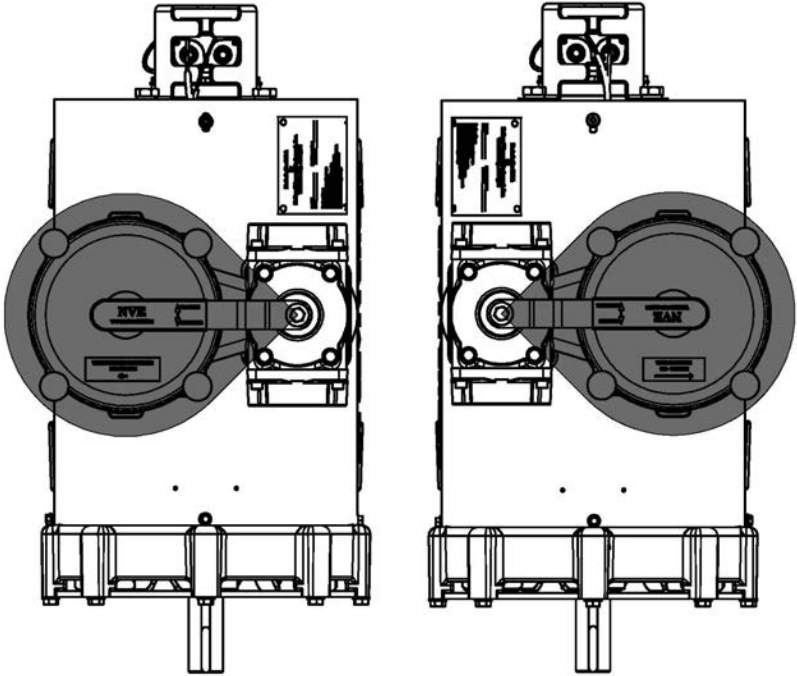

Counter Clockwise  
Rotation

Clockwise  
Rotation

# Contents

<b>Introduction</b>	<b>5</b>
General Information.....	5
<b>Limited Warranty</b>	<b>6</b>
Warranty.....	6
<b>607 Challenger</b>	<b>9</b>
Application.....	9
Pump Specifications.....	9
System Requirements.....	10
Drive System.....	11
Factory Settings.....	11
Adjusting Factory Oil Settings.....	12
<b>Operating Instructions</b>	<b>13</b>
Normal Operation.....	13
Recommended Lubricant.....	14
Maintenance.....	15
Cold Weather Operation.....	16
<b>Troubleshooting</b>	<b>17</b>
Pump overheats.....	17
Pump uses too much oil.....	17
Pump doesn't turn.....	17
No vacuum.....	18
System Troubleshooting.....	18
Making a vacuum tester.....	19
<b>Parts Breakdown</b>	<b>20</b>
607 Challenger Series Vacuum Pumps Parts List.....	20
607 Fan Cooled Parts Diagram.....	23
607 Liquid Cooled Parts Diagram.....	24
607 SV Parts Diagram.....	25
607 Fan Cooled Parts Oil Line Routing.....	26
607 Liquid Cooled Oil Line Routing.....	27
Automatic Oil Pump Parts List (Three Outlet).....	28
Automatic Oil Pump Parts Diagram (Three Outlet).....	29
Automatic Oil Pump Parts List (Four Outlet).....	30
Automatic Oil Pump Parts Diagram (Four Outlet).....	31

# Introduction

## General Information



### About National Vacuum Equipment

***Congratulations!*** You now own a quality vacuum/pressure pump proudly manufactured in the U.S.A. by National Vacuum Equipment, Inc. You have not only acquired a superior piece of equipment from a qualified dealer, you have hired a team of vacuum experts. We stand ready to work with your dealer to answer your questions and provide you with the information necessary to keep your equipment in peak working condition.

Thank you for using National Vacuum Equipment.

## Our Mission

We are dedicated to the manufacture and wholesale distribution of quality vacuum system products at a reasonable price, on a timely basis. We are a “one-stop shop” for manufacturers and distributors of vacuum equipment.

## Our History

National Vacuum Equipment, Inc. was founded in 1980 by Bruce Luoma. The Company started as a retailer of vacuum pumps. Soon after it started, the Company secured the rights to exclusive distribution of the Battioni vacuum pumps in North America. This helped the Company to evolve into its current status as a wholesale supplier.

To reach the goal of becoming a full service supplier of vacuum system components, the Company began fabrication its own line of componentry, purchased and developed its own line of vacuum pumps, and began purchasing for resale various valves and accessories.

Today, NVE has full service machine, fabrication and powder-coating shops complete with CNC-controlled production equipment designed for close tolerance work. The company has a highly trained staff all of whom are dedicated to quality.

# Limited Warranty

## 607 Challenger



---

## Warranty

### National Vacuum Equipment, Inc.

Guarantees that the product it provides is free of manufacturer's defects, including materials and workmanship. Properly installed and maintained product is warranted for a period of one (1) year subject to the following conditions:

1. A properly completed warranty registration card must be received by us within 30 days of sale to end user for pump sales to be considered warrantable. All pumps received for warranty consideration must retain the original NVE serial number tag.
2. The one (1) year period shall begin the day the product is shipped from our warehouse, unless we are provided with an authentic copy of the original resale invoice, in which case the one (1) year period shall begin at such invoice date.
3. The covered product must be used in an application for which it was intended. We do not recommend our product for particular uses or applications.
4. Vane breakage, or damage caused by vane breakage, is not warrantable.
5. Damage caused by improper use or lack of proper maintenance is not warrantable.
6. Manufacturer's liability under this or any other warranty, whether express or implied, is limited to repair of or, at the manufacturer's option, replacement of parts which are shown to have been defective when shipped

7. Manufacturer's liability shall not be enforceable for any product until National Vacuum Equipment, Inc. has been paid in full for such product.
8. Except to the extent expressly stated herein, manufacturer's liability for incidental and consequential damage is hereby excluded to the full extent permitted by law.
9. Manufacturer's liability as stated herein cannot be altered except in writing signed by an officer of National Vacuum Equipment, Inc.
10. Certain products provided by National Vacuum Equipment, Inc. are covered by their respective manufacturer's warranties (e.g., engines used in the NVE engine drive packages). These products are not covered by the National Vacuum Equipment, Inc. Manufacturer's Warranty.
11. Final assemblers responsibility. NVE goes to great lengths to insure the quality and proper functionality of the products it supplies. Many products we supply are purchased for resale or are impossible or impractical to test prior to the installation of the item in a vacuum system. It is therefore the responsibility of the final assembler to thoroughly test the vacuum system and components supplied to the assembler by NVE prior to the delivery of the final product to the end user.
12. Not responsible for pump coupling tightness or alignment. Customer needs to inspect periodically to ensure proper alignment and to check tightness of set screws.

Any items found to be defective after delivery to the end user that should have been discovered prior to delivery will qualify replacement of the defective part only with absolutely no compensation for outside labor or travel expenses. Any subsequent damage to other components caused by the defective part will be the sole responsibility of the assembler.

---

## Warranty Procedures

### **Should a potential warranty situation arise, the following procedures must be followed:**

- Contact your dealer or NVE immediately upon the occurrence of the event and within the warranty period.
- Customer must receive a return goods authorization (RGA) before returning product.
- All serial-numbered products must retain the NVE serial number tag to be qualified for warranty.
- Product must be returned to NVE intact for inspection before warranty will be honored.
- Product must be returned to NVE freight prepaid in the most economical way.
- Credit will be issued for material found to be defective upon our inspection, based upon prices at the time of purchase.



# 607 Challenger

## Model-Specific Information



## Application

### Designed for extended operation

- Duty cycle will vary depending on several factors, such as altitude, RPM & ambient temperature.
- The 607 Challenger is a severe duty vacuum pump, designed to be used in liquid waste pumping systems where extended operation is desired.
- Proven applications are:
  - Oil field
  - Septic
  - Restaurant Grease
  - Industrial Waste

## Pump Specifications

### 607 Calculated Flow Data

RPM		Pressure (PSI)				Free Flow	Vacuum (in Hg)					
		20	15	10	5		0	5	10	15	20	25
1500	Hp	34	32	29	27	23	23	22	21	20	19	19
	CFM	282	291	301	331	357	348	338	331	310	282	244
1250	Hp	29	27	24	23	20	20	19	16	15	14	14
	CFM	229	237	244	269	290	282	275	269	252	229	198
1000	Hp	26	23	20	18	15	15	14	14	13	12	12
	CFM	178	184	190	209	226	220	214	209	196	178	155

---

## System Requirements

### High Quality Components

- The 607 Challenger is a high performance vacuum pump and requires compatible, high quality components as manufactured by NVE.

### Shutoffs

- We recommend an 8" cage and a 6" S.S. ball which is standard in all of our primary and secondary shutoffs.

### Hose

- Use 3" or larger hose to plumb your system. We recommend you use a hose that can withstand high temperatures such as hot tar-asphalt hose.

### Pressure and Vacuum Relief Valves

- A properly adjusted pressure relief and vacuum relief valves should also be incorporated in the system between the secondary shutoff and the pump.
- The relief valves should be set to where the pump operates at a maximum temperature of 375 degrees Fahrenheit.

## Pressure and Vacuum Relief Valve Setting Instructions

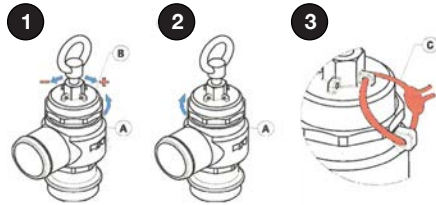

### Pressure Relief Valve

- Picture 1. 1. Unscrew the lock nut "A"  
2. Turn the spring-tightener "B"

Picture 2. Once obtained the desired pressure, screw down the lock nut "A"

Picture 3. Fix the setting, using the rings "C" Situated on the body and on the spring tightener

### Vacuum Relief Valve

1. Remove the protection cap "A"
2. Turn the spring-tighter "B", through a spanner "C", Clockwise to increase the pressure, Anti-clockwise to reduce the pressure
3. Once obtained the desired pressure, screw down the lock nut "D"
4. Screw down the protection cap and fix it using the rings "E" situated on the valve body and on the cap

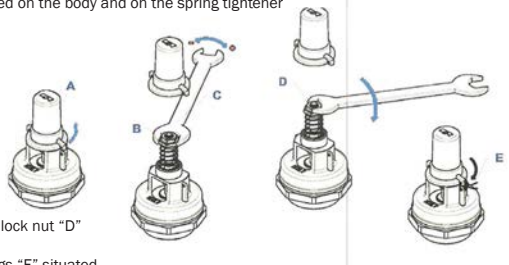

---

## **Drive System**

- The pump should be mounted on a level, horizontal surface, secured with grade 8 fasteners.
- The drive system should be sized to supply the required horsepower to the pump plus a reserve to insure long life.
- The P.T.O. must be slowly engaged or it will damage the pump and drive components.
- Make certain that all shafts, pulleys or turning parts are properly guarded.
- Check the ratio of the drive system prior to installation to verify that the pump will be turning at the proper speed.

---

## **Direction of Rotation**

- The direction of rotation and RPM are marked on the front of the pump.
- The direction of rotation required by your drive system should be determined prior to ordering the pump. Please pay special attention to the orientation of the final filter, which varies with rotation.

---

## **Factory Settings**

- The automatic lubrication pumps are set at the factory during pump testing and should require no further adjustment during pump installation. The pump should consume 12 oz. - 15 oz. of oil per hour. Please contact us if oil usage is outside of these parameters.
- It is the responsibility of the installer to ensure proper vacuum and pressure settings and RPM.

---

## Adjusting Factory Oil Settings

The automatic oil pump is a metered piston-type pump. Before adjusting the oilers, please follow these basic trouble shooting steps.

1. Make sure the pump (tank) is not under vacuum between jobs.
2. Fill the oil tank to the top at night. Check the oil level before service the next day to ensure no internal leaking.
3. Monitor the period of use and measure the oil required to replenish the tank (this should be 12 oz. - 15 oz. per hour). Compare this with the oil collected from the oil catch muffler.

If after following these steps it is determined that an oil adjustment is needed, then please follow the basic steps below.

1. Disconnect the hose running from your remote oil reservoir to the pump intake.
2. Oil flow is changed by adjusting the length of the stroke of the piston.
3. To adjust the oil rate, remove cap [P16]. Under this cap you will find a jam nut [P15] and adjusting screw [P11]
4. Loosen the jam nut and turn adjusting screw clockwise to reduce oil flow or counterclockwise to increase oil flow.
5. When making adjustments do so one turn of the screw at a time and test before making further adjustments.

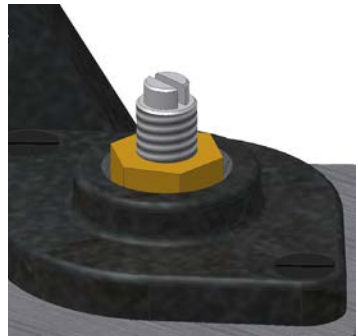

# Operating Instructions

## 607 Challenger

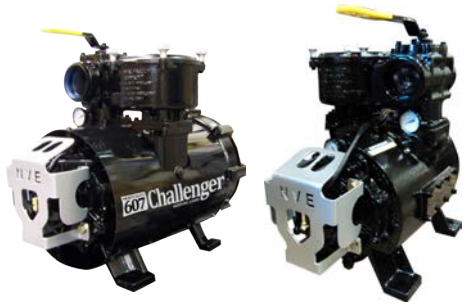

---

### Normal Operation

#### Oil Reservoir

- Check oil reservoir daily and fill as required.
- Drain and clean periodically depending on service.

#### Temperature

- Check exhaust temperature. It must not exceed 375 degrees Fahrenheit at any time.

#### Recommended RPM

- Do not operate the pump faster than the recommended rpm of 1250. 1500 RPM is for intermittent use only.
- Too low of an RPM can cause the vanes to clatter (inconsistent contact with the housing) causing wear.

#### Suction Valve

- To operate the suction valve, move the handle in the appropriate direction for either vacuum or pressure; center is neutral.

#### Vacuum Levels

- Do not operate your pump for extended periods of time at vacuum levels which cause the pump to exceed 375 degrees Fahrenheit exhaust gas temperature.

#### Guards

- Make certain all guards are in place prior to running your pump. Think Safety!

---

## Recommended Lubricant

- We recommend that turbine oil be used in our pumps. Turbine oil is much more resistant to breakdown due to heat than normal motor oil, thereby avoiding the problems associated with motor oil such as lacquering and excessive wear.
  
- Acceptable oils include:
  1. \*NVE ISO 68 Oil
  2. Penzoil Penzabell 68 T.O.
  3. Shell Turbo 68
  4. Mobil D.T.E. Heavy - Medium
  5. Texaco Regal R & O 68

\* NVE ISO 68 Oil is our recommended pump oil for the Challenger series vacuum pumps. Challenger Vacuum Pump Oil is sold by the case, six 1 gallon containers of oil per case.

---

## Maintenance

### Washing

- Periodically wash the mud and dirt off of your pump as it must be clean to allow heat to radiate from it.

### Flushing

We recommend periodic flushing of your pump. To do this:

1. Connect the hose to the flush valve located on the side of the inlet port.
2. Put the end of the hose in a one pint container of diesel fuel. Start your pump and run as slow as possible.
3. With the suction valve in the vacuum position, monitor the diesel flow to your pump.
4. When the diesel fuel is gone, switch the suction valve to neutral and run the pump for 2 minutes.
5. Speed the pump up to normal RPM, switch the suction valve to vacuum.
6. Remove the hose and close the valve.
7. Properly dispose of used oil and flushing fluid.

### Checking Vane Wear

- We recommend checking vane wear at least every 12 months.
- A new vane is flush with the outside diameter of the rotor.
- Remove the plug from the vane check port, insert a rod to rotor O.D., rotate rotor until the rod falls into one of the vane slots. If the rod falls more than a 1/4" into any of the 7 vane slots, it's time to replace the vanes.
- Vanes should be replaced in sets and it is always a good idea to have an extra set of vanes on hand for emergencies.

---

## Cold Weather Operation

### **Confirm pump is not frozen.**

- Prior to engaging the pump, turn by hand to confirm it is not frozen.

### **If pump is frozen, thaw it.**

- If the pump is frozen, thaw it out by moving the truck into a heated building.

### **Avoid freezing problems**

- You can avoid freezing problems by putting a small amount of diesel fuel into the pump at the end of the day.



# Troubleshooting

## NVE 607 Vacuum Pump



---

### Pump overheats

- No oil in pump
- Oil adjustment set too lean
- RPM too fast
- Prolonged operation at excessive vacuum or pressure levels
- Pump is dirty
- Inlet filter is clogged.

---

### Pump uses too much oil

- Oil pump set too rich
- Leaving pump under vacuum between jobs
- Product running through pump

---

### Pump doesn't turn

- Broken vane or bearing
- Pump is frozen
- Problem in the drive train

---

## No vacuum

- Suction valve is in neutral
- Worn seals or vanes
- Pump is not turning fast enough
- Check valve or suction valve is clogged
- Leak in the tank or fittings
- Collapsed hose between the pump and shutoffs
- Inlet filter clogged

## System Troubleshooting

### Locating the source of the trouble

If you notice a decrease in pump performance, start troubleshooting at the pump.

- Remove the suction and discharge hoses at the pump.
- Start the pump and run it in vacuum only at its normal rpm
- Check the vacuum level at the pump inlet. The 607 Challenger in new condition will develop 27-28.5" hg.
- If the pump checks out ok, check the vacuum level at the secondary, then the primary shutoff. Keep working your way back until you find the problem.

**For rebuild instructions please visit our website at [www.natvac.com](http://www.natvac.com) or call us at 800-253-5500**

---

## **Making a vacuum tester**

1. Procure a flange to mount on your 4-way valve, a short 3" pipe nipple, a 3" pipe cap and a vacuum gage.
2. Drill and tap a 1/4" N.P.T. thread in the pipe cap.
3. Assemble the flange, nipple, pipe cap and vacuum gage.
4. Remove a flange from the four-way valve on your pump.
5. Start the pump and confirm the location you have chosen to test from is at vacuum.
6. Using the existing O-ring, fasten the testing flange to your pump.
7. Start your pump and read the vacuum level on the gauge.

## NVE 607 Challenger Series | Parts List

ITEM	QTY	PART NUMBER	DESCRIPTION
1A	1	120-001-367	HOUSING, 367 PINNED ENDPLATE
1B	1	120-001-607A	HOUSING, 607A MACHINED
1C	1	120-001-367-L	HOUSING, 367 WATER COOLED
2	1	120-005-367	ROTOR, HVY DTY 360 SLOTTING
3	2	120-009-367	SEAL SLEEVE, 360HD & 367
4	1	120-003-003 120-003-002	ENDPLATE, CCW MACHINED 607 (CW PUMP) ENDPLATE, CW MACHINED 607 (CCW PUMP)
5	2	120-045-001	SPRING, WAVE WIRE 3.50"
6	2	120-021-367	COVER PLATE, 367 WATER JACKET
7	1	120-046-367	SPRING, CHECK VALVE 367
8	1	120-041-367	POPPET, 3" CHECK VALVE
9	1	120-042-367	RETAINER RING, 3" (360 & 367)
10	1	120-320-001	HOUSING, FILTER-INTEGRAL
11	1	120-062-001	PLUG, 4-WAY, 607
12	1	120-064-003	O-RING, 2-240 VITON
13	1	120-065-002	TOWER, 3" RM MACHINED
14	2	120-063-367	FLANGE, 3" NPT
15	1	120-064-004	O-RING, 2-265 VITON
16	1	120-310-001	COVER, FILTER 607/866
17	1	120-220	THERMOMETER, 50- 400 DEG, 2" FACE, 2.5" STEM, 1/4" - 18NPT
18	1	120-060-001	HANDLE, 367 GEN 2
19	2	120-064-002	O-RING, 2-214 VITON
20	2	120-064-001	O-RING, 2-154 VITON
21	1	120-314-001	FILTER ELEMENT, 60 MESH
22	1	120-045	4-WAY FV SPRING (COMPRESSED)
23	2	120-055-367	GASKET, FRONT BEARING COVER
24	7	120-007-367	VANE: 350, 360 & 367
25	4	120-018-367	SEAL, 60X72X8 VITON SGL LIP
26	2	120-039-367	GASKET, FLANGE INT/EXH
27	2	120-004-367	GASKET, 367 END PLATE
28	2	120-053	SEAL, 40X52X7 VITON
29	2	120-019-367	BEARING, NJ 308 L1308B
30	1	120-102	VALVE, DRAIN 1/8" NPT
31	2	120-058	PLUG, BRASS 1/8" NPT, HEX HD.
32	1	320-LF8	DRIVE TAB
33	1	320-LW32BD 320-LW32BS	OIL PUMP, 4 PORT (CW PUMP) OIL PUMP, 4 PORT (CCW PUMP)
34	1	320-R31	GASKET, OIL PUMP
35	2	120-022-367	GASKET, 367/506 COVER PLATE
36	1	120-006	KEY, 3/8" X3/8" X 2
37	1	120-059	PLUG, BRASS 1/4" NPT, HEX HD.
38	1	120-220-1	1/8" NPT THERMOMETER 220 F
39	1	120-047-1	DRAIN PLUG, 3/4" NPT MAGNETIC
40	1	120-047	DRAIN PLUG, 3/4" NPT
41	1	120-107	TAG, SERIAL NUMBER, BRASS

## NVE 607 Challenger Series | Parts List *Continued*

ITEM	QTY	PART NUMBER	DESCRIPTION
42	1	120-054-001	BEARING COVER, 367P
43	1	120-060-002	GRIP, HANDLE W/ LOGO
44	1	120-079-001	GUARD, OIL PUMP 607 POWDERCOAT
45	5	320-408-001	ADAPTER, ELBOW 1/8 BSPTM-NTPF
46	1	120-049	BUSHING, 3/4"NPTX1/8"NPT
47	3 4	320-409-003	P-CLIP, OIL LINE 1/4" X 5/16 (100-607-FD, 100-607-FS, 100-607A-FS & 100-607-LD) P-CLIP, OIL LINE 1/4" X 5/16 (100-607-LS)
48	6	320-408-004	FITTING, STRT 1/8 NPT-TUBE
49	1	120-054-002	BEARING COVER, OIL PUMP 607
50	1	120-101-367-D 120-101-367-S	DECAL, RPM-CW 607 DECAL, RPM-CCW 607
51	4	120-312-002	KNOB, 5/16-18UNC
52	2	320-408-005	FITTING, ELBOW 1/8 NPT-TUBE
53	8'	320-407-001	TUBE, 1/8" OD PFA
54	5'	320-409-002	OIL LINE PROTECTOR, 1/4" FIBERGLASS
55	1	310-LP5	1/4" HOSE BARB X 1/8" NPT STRAIGHT
56	1	320-408-002	ADAPTER, ELBOW 1/8 MNPT-FNPT
57	1	120-103-367	DECAL, IMPORTANT 375F
58	1	120-003-002 120-003-003	ENDPLATE, CW MACHINED 607 (CW PUMP) ENDPLATE, CCW MACHINED 607 (CCW PUMP)
59	1	120-071-367-D 120-071-367-S	SHROUD, 367 TOP CW SHROUD, 367 TOP CCW
60	1	120-070-367	SHROUD, LOWER, 367
61	1	120-076	KEY, 3/8" X 3/8" X 1"
62	1	120-074-001	FAN SHROUD, 367 SHORT
63	1	120-083-002 120-083-001	FAN ASSY, CW 607 FAN ASSY, CCW 607
64	1	120-073	FAN GUARD, 367, 460, 466 & 506
65	1	120-105	TAG, LARGE, NVE SERIAL NUMBER
66	1	120-106-367-D	PLATE, CW
67	1	120-077-367	SHROUD SUPPORT, 360 & 367
68	1	120-100-607	DECAL, 607 CHALLENGER HD
69	1	120-071-607A-S	TIN KIT, 607A
69A	1	120-071-607A-S-1	TIN, UPPER 1 CCW - 607A
69B	1	120-071-607A-S-2	TIN, UPPER 2 CCW - 607A
69C	1	120-071-607A-S-3	SHROUD, LOWER, 607A
69D	1	120-071-607A-S-4	BRACKET, 607A TINS
70	1	120-100-607A	DECAL, 607 SIDE MOUNT
71	1	120-101-607A-S	DECAL, WARNING 607A
72	1	120-101-001	DECAL, NATVAC.COM
73	1	120-351-001	LIFT EYE, 3/8-16 PLATED
74	1	120-104-367	DECAL, WARNING-GUARDS
200	1	310-LP5	HOSE BARB TO MALE PIPE
201	1	310-LP6	HOSE BARB, 1/4 TO 1/4NPT STRT
202	5	320-407-003	OIL LINE, BLK 1/4" ID 30R7
203	1	320-083-009	OIL TANK FILTER, 100 MESH
204	1	320-082-001	OIL TANK, 5QT, W/LOGO

## NVE 607 Challenger Series | Parts List *Continued*

ITEM	QTY	PART NUMBER	DESCRIPTION
303	4	HHCS - 5/16-18 UNC X 2 FT	HHCS - 5/16-18 UNC X 2 FULL THREAD
304	8	SHCS - 5/16-18 UNC X 1	SHCS - 5/16-18 UNC X 1
305	1	HHCS - 3/8-16 UNC x 0.75	HHCS - 3/8-16 UNC X 0.75
306	10	HHCS - 3/8-16 UNC X 1.75	HHCS - 3/8-16 UNC X 1.75
307	4	HHCS - 1/2-13 UNC X 1.00	HHCS - 1/2-13 UNC X 1.00
308	36	LW - 5/16	LOCK WASHER, 5/16
309	3	LW - 3/8	LOCK WASHER, 3/8"
310	4	LW - 1/2	LOCK WASHER, 1/2
311	23	FW - 3/8	FLAT WASHER, 3/8"
312	6	HHCS - 3/8-16 UNC X 2.25	HHCS - 3/8-16 UNC X 2.25
313	8	HHCS - 3/8-16 UNC X 0.50	HHCS - 3/8-16 UNC X 0.50
314	4	RVT 1/8 D X 1/8L	BLIND RIVET, 1/8 DIA X 1/8 GRIP, ALUM
315	1	SHCS - 5/16-24 UNF X 1.25	SHCS - 5/16-24 UNF X 1.25
316	14	TAPSCR - 1/4-14 X 0.75	HEX HEAD SELF TAPPING SCREW 1/4-14
317	1	HHCS 1/4-20 UNC X 2.75	HHCS 1/4-20 UNC X 2.75
318	2	FW - 1/4 USS	FLAT WASHER - 1/4" USS
319	1	BHCS - 1/4-20 UNC X 0.50	BHCS - 1/4-20 UNC X 0.50
320	1	HEX NUT - 3/8 UNC	HEX NUT - 3/8 UNC

# NVE 607 Challenger Fan Cooled | Parts Diagram

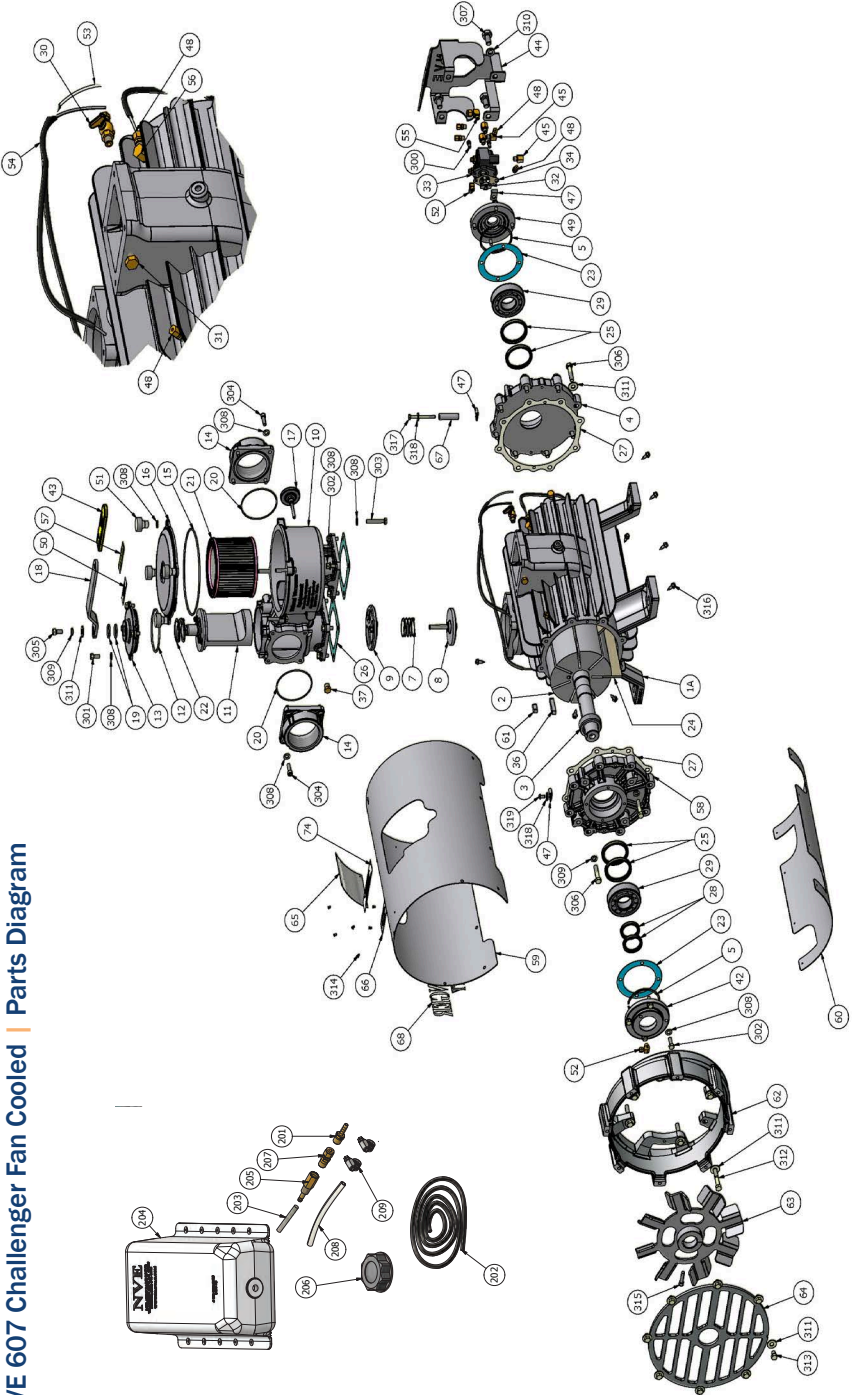

NVE 607 Challenger Liquid Cooled | Parts Diagram

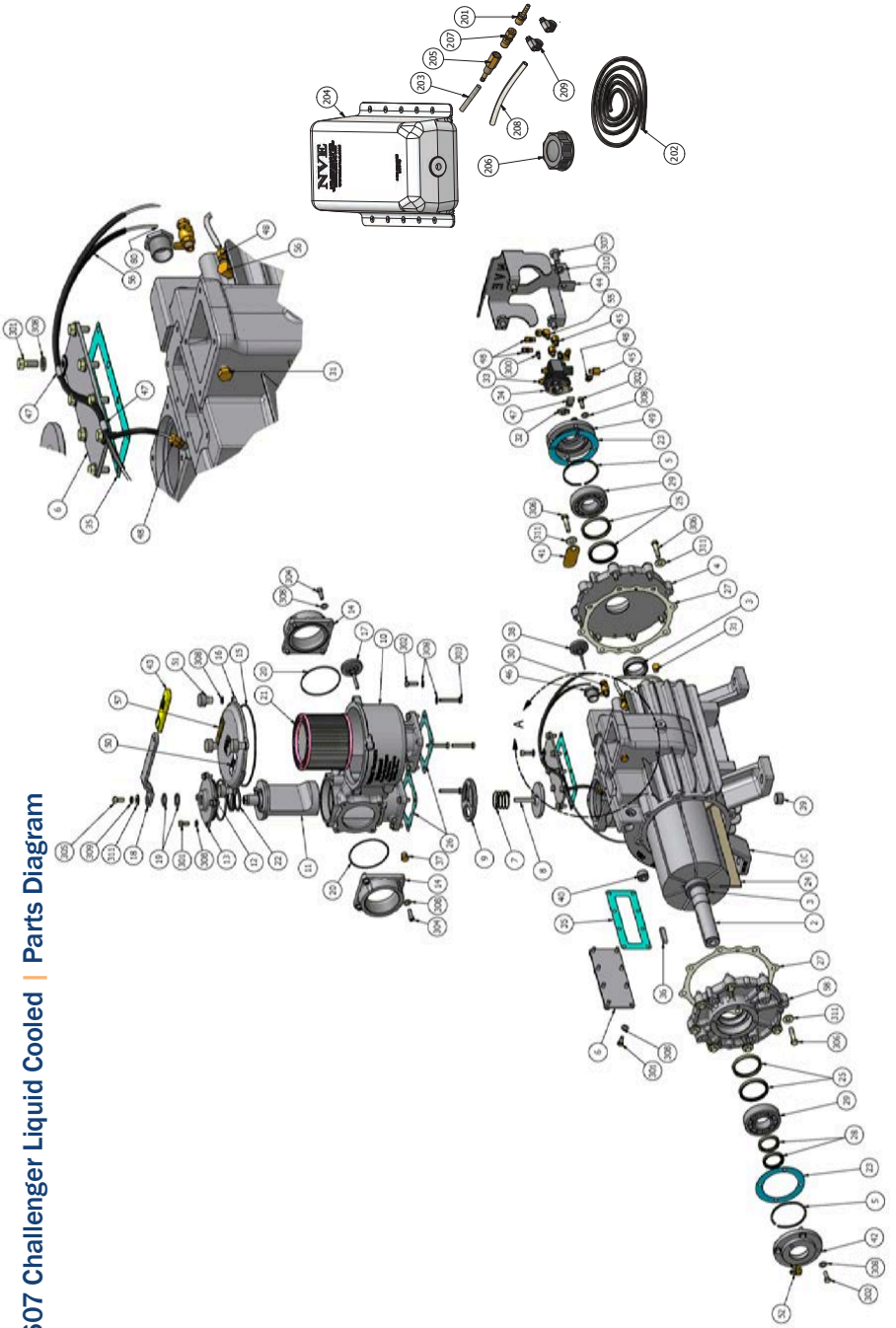



NVE 607 SV Challenger Fan Cooled | Parts Diagram

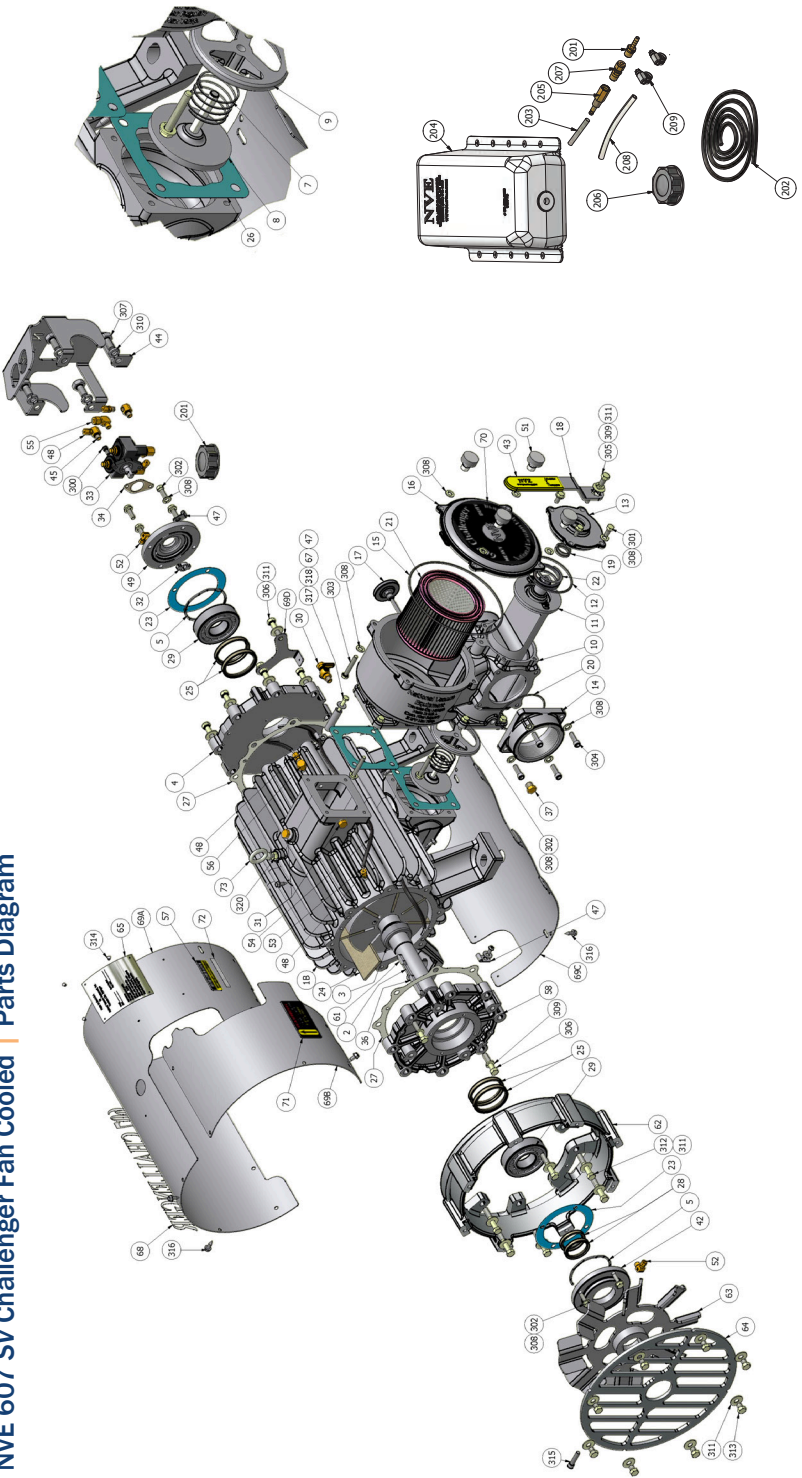

# 607 Challenger - Fan Cooled - Oil Line Routing

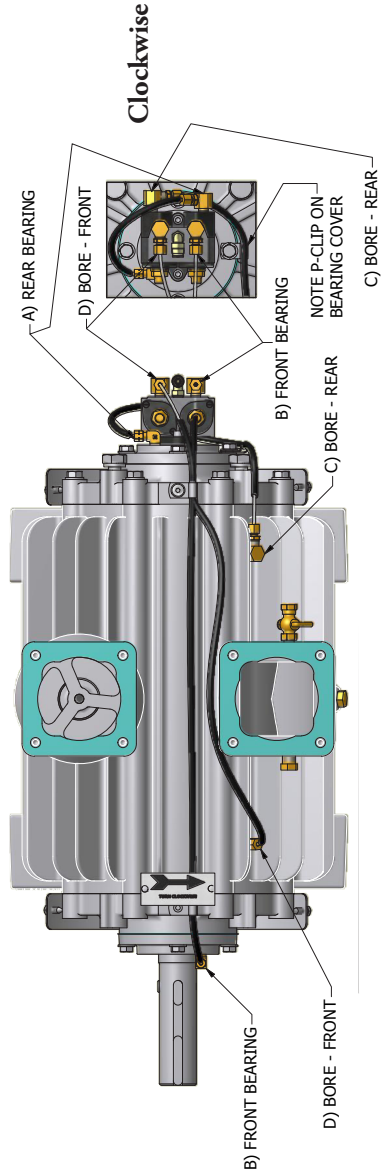
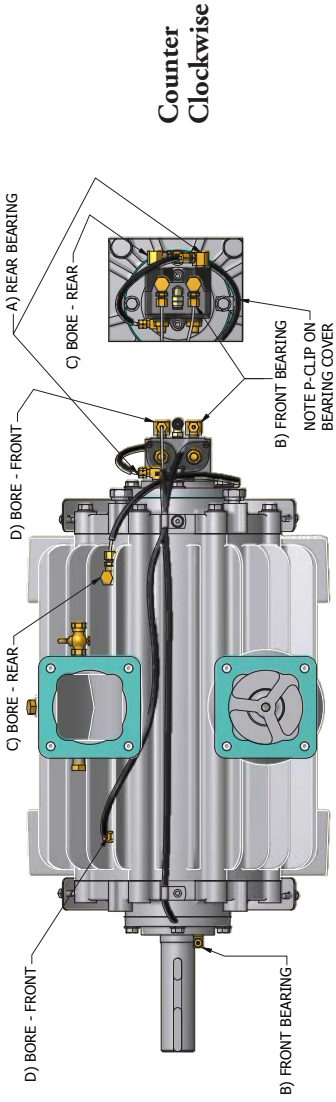

# 607 Challenger - Liquid Cooled - Oil Line Routing

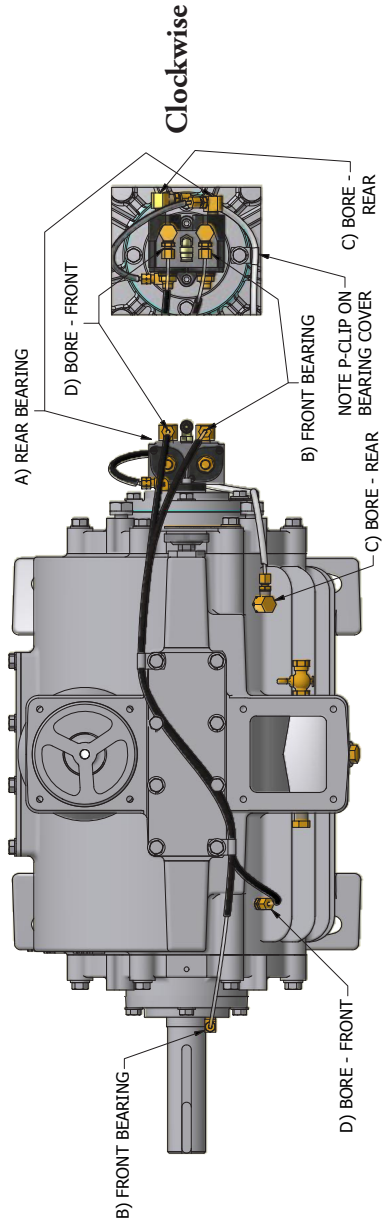
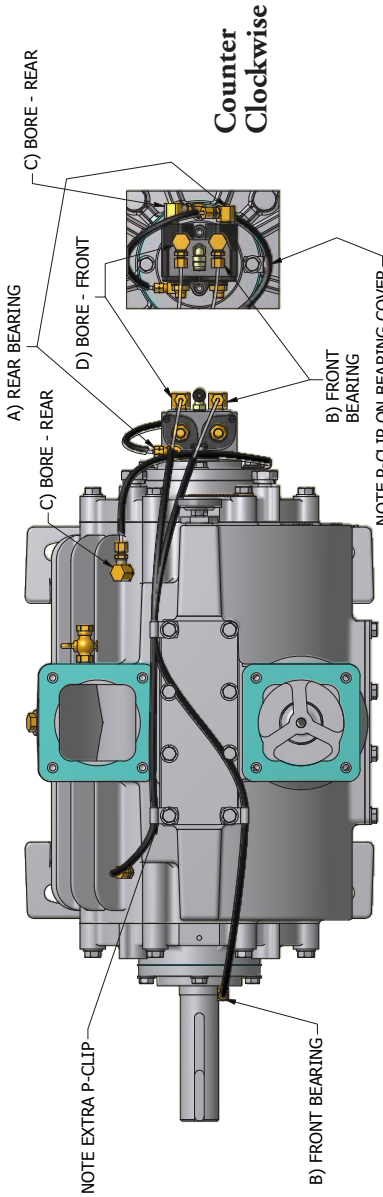

# Parts List – Automatic Oil Pump

*See Parts Diagram Opposite.*

Part #	Description
320-P3CW	Pump Body (Clockwise)
320-P3CCW	Pump Body (Counterclockwise)
320-P5	Driven Gear (Clockwise)
320-PA5	Driven Gear (Counterclockwise)
320-P6	Spring
320-P7	Driving Gear (Clockwise)
320-P7CCW	Driving Gear (Counterclockwise)
320-P8	Seal
320-P9	Plug
320-P10	Retainer
320-P11	Adjusting Screw
320-P12	Gasket
320-P13	Lid
320-P14	Screw
320-P15	Jam Nut
320-P16	Cap

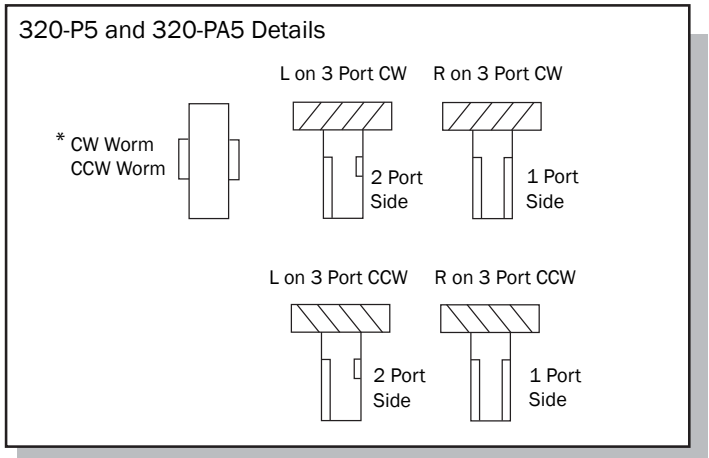

Detail - Key # 26  
**Automatic Oil Pump**

**Three Outlet Type**

Part # 320 - LW32AD    Clockwise  
Part # 320 - LW32AS    Counterclockwise

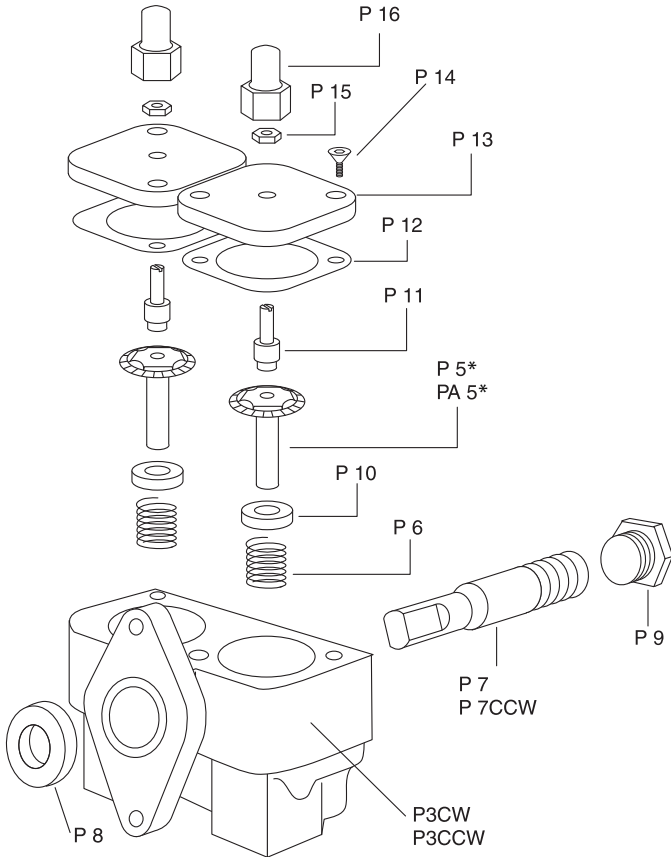

# Parts List – Automatic Oil Pump

See *Parts Diagram Opposite*.

*This oil pump is in all pumps with a Serial # that is 31845 or above.*

Part #	Description
320-P4CW	Pump Body (Clockwise)
320-P4CCW	Pump Body (Counterclockwise)
320-P5	Driven Gear (Clockwise)
320-PA5	Driven Gear (Counterclockwise)
320-P6	Spring
320-P7	Driving Gear (Clockwise)
320-P7CCW	Driving Gear (Counterclockwise)
320-P8	Seal
320-P9	Plug
320-P10	Retainer
320-P11	Adjusting Screw
320-P12	Gasket
320-P13	Lid
320-P14	Screw
320-P15	Jam Nut
320-P16	Cap

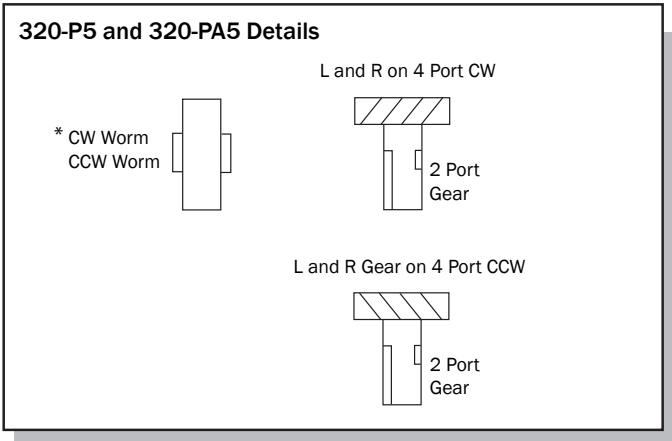

Detail - Key # 26

# Automatic Oil Pump

## Four Outlet Type

Part # 320 - LW32BD    Clockwise  
Part # 320 - LW32BS    Counterclockwise

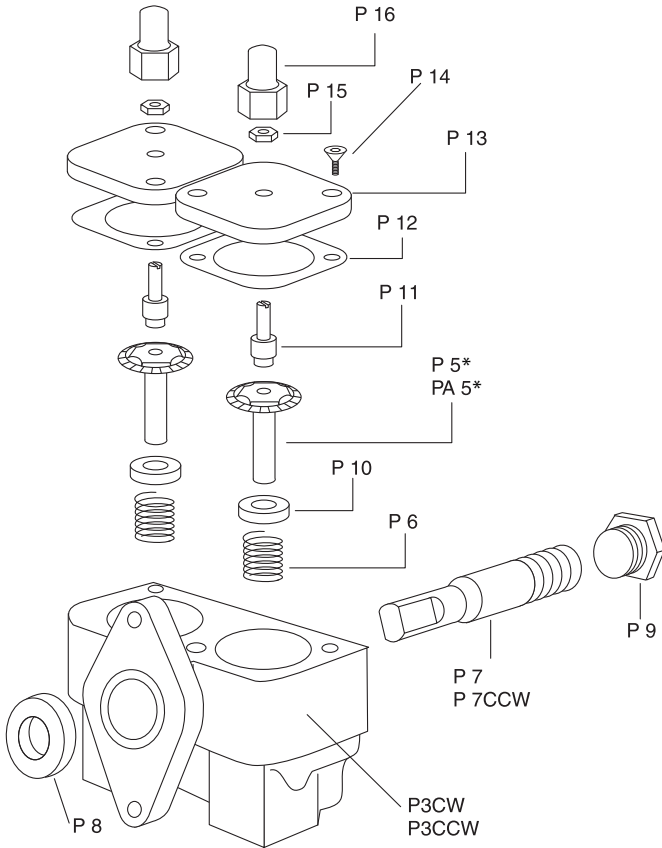

# NVE

**National Vacuum Equipment, Inc.**

P.O. Box 685  
Traverse City, MI 49685 USA

231.941.0215 Phone  
231.941.2354 Fax

**800.253.5500 | [www.natvac.com](http://www.natvac.com)**